

Clamp mountings

Aluminium

SPECIFICATION

Aluminium

- matt, slide ground **MT**
- anodized, black **ELS**

Socket cap screw DIN 912

Stainless Steel AISI 304

Clamping kits GN 511 (see page 1893)

- Zinc die casting
- Inserts / Distance bushings, Stainless Steel AISI 303

INFORMATION

Attachment clamp mountings GN 478 are primarily designed for mounting sensor holders GN 479 (see page 1895) and retaining plates GN 479.1 (see page 1896). They are fitted with a central thread and with $d_1 = B15$ bore and higher, an additional bore template $4 \times M4$. The standard clamping screw is a socket cap screw with hexagonal socket DIN 912. It can be replaced by an clamping kit GN 511 (see page 1893) (see table of dimensions).

TECHNICAL INFORMATION

- Stainless Steel characteristics (see page A26)

ACCESSORY

- Clamping kits GN 511 (see page 1893)

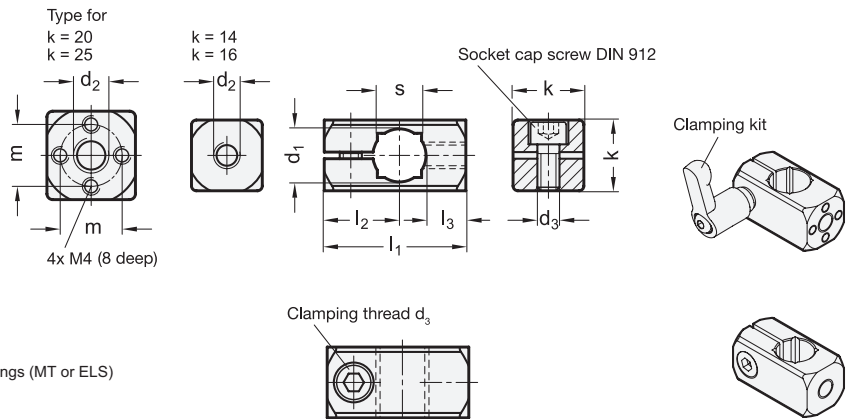

* Complete with Finish of the Clamp mountings (MT or ELS)

| | |
|--------------------|-----------------|
| MT | ELS |
| matt, slide ground | anodized, black |

GN 478

| Description | d1 For shaft tolerance h11 | d2 | d3 | k | m | l1 | l2 | l3 | s | Clamping kits for d3 | ⚖ |
|------------------|----------------------------|------|-----|----|----|----|------|------|----|----------------------|----|
| GN 478-B8-M5-* | B 8 | M 5 | M 4 | 14 | - | 25 | 13,5 | 7,5 | - | GN 511-M4-14 | 11 |
| GN 478-B10-M5-* | B 10 | M 5 | M 5 | 16 | - | 30 | 17 | 8 | 8 | GN 511-M5-16 | 16 |
| GN 478-B10-M6-* | B 10 | M 6 | M 5 | 16 | - | 30 | 17 | 8 | 8 | GN 511-M5-16 | 16 |
| GN 478-B10-M8-* | B 10 | M 8 | M 5 | 16 | - | 30 | 17 | 8 | 8 | GN 511-M5-16 | 16 |
| GN 478-B12-M5-* | B 12 | M 5 | M 5 | 16 | - | 32 | 17 | 9 | 10 | GN 511-M5-16 | 16 |
| GN 478-B12-M6-* | B 12 | M 6 | M 5 | 16 | - | 32 | 17 | 9 | 10 | GN 511-M5-16 | 17 |
| GN 478-B12-M8-* | B 12 | M 8 | M 5 | 16 | - | 32 | 17 | 9 | 10 | GN 511-M5-16 | 17 |
| GN 478-B15-M6-* | B 15 | M 6 | M 6 | 20 | 14 | 40 | 20,5 | 12 | 12 | GN 511-M6-20 | 32 |
| GN 478-B15-M8-* | B 15 | M 8 | M 6 | 20 | 14 | 40 | 20,5 | 12 | 12 | GN 511-M6-20 | 31 |
| GN 478-B16-M6-* | B 16 | M 6 | M 6 | 20 | 14 | 40 | 20,5 | 11,5 | - | GN 511-M6-20 | 31 |
| GN 478-B16-M8-* | B 16 | M 8 | M 6 | 20 | 14 | 40 | 20,5 | 11,5 | - | GN 511-M6-20 | 30 |
| GN 478-B20-M8-* | B 20 | M 8 | M 6 | 25 | 17 | 45 | 21,5 | 12 | 16 | GN 511-M6-25 | 51 |
| GN 478-B20-M10-* | B 20 | M 10 | M 6 | 25 | 17 | 45 | 21,5 | 12 | 16 | GN 511-M6-25 | 50 |

Weight ELS